

Exam 2 2049H Spring 2009

Name:

Scores: 1

2

3

4

5

Total:

Problem 1 (15 points)

Parallel capacitors are half filled by dielectric materials as shown below. (a) calculate the capacitances in terms of ϵ_0 , A , d . (b) Which capacitor has higher capacitance?

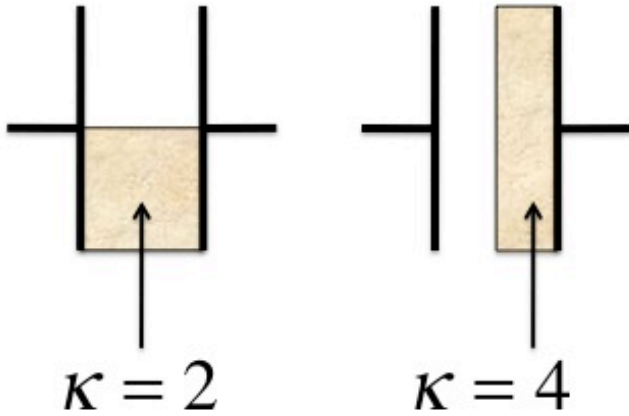

Problem 2 (20 points)

Calculate I_1 and I_2 for the circuit shown left.

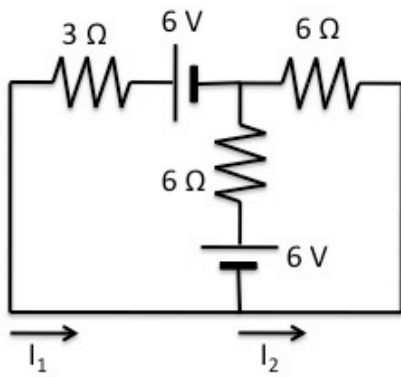

Problem 3 (30 points)

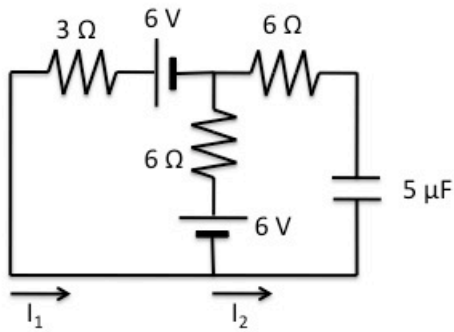

(a) Calculate I_1 in the steady state ($t=\infty$). Note that at this point I_2 should be equal to zero.

(b) Calculate the charge stored in the capacitor in the following circuit.

(c) What is the characteristic charging time (the RC time constant) for the capacitor?

Problem 4 (20 points)

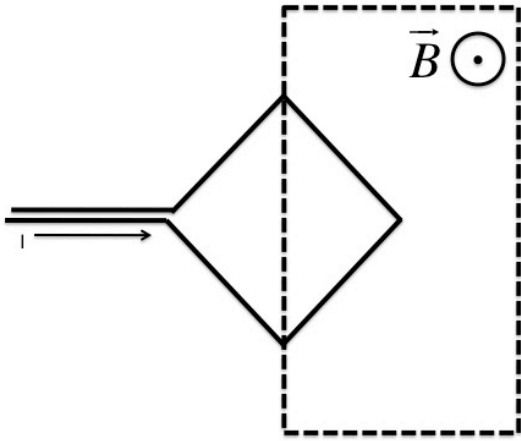

Calculate the force due to magnetic field on a wire which has been shaped into a square shape as shown left. The square has sides of 1 m, the magnetic field is 0.1 T, and the current is 1 A. Magnetic field is only present in the dotted square as indicated in the figure.

Problem 5 (15 points)

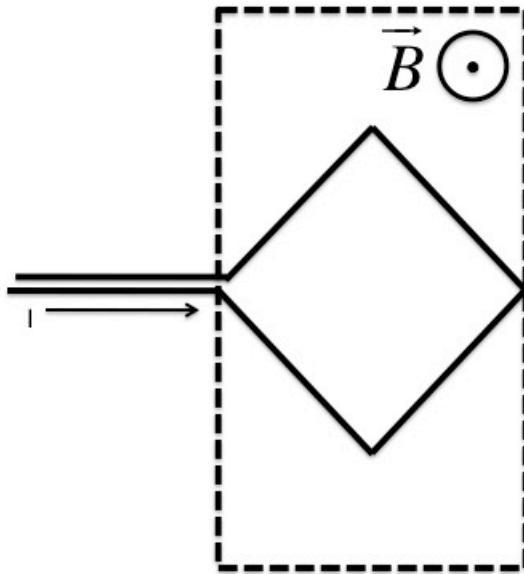

Calculate the force if the metal square has been inserted further into the magnetic field. Everything else remains the same. The square has sides of 1 m, the magnetic field is 0.1 T, and the current is 1 A. Magnetic field is only present in the dotted square as indicated in the figure.